

## GENERAL

**ALIAMASS** ACF6000 Series uses the Coriolis effect as a technique for liquid mass flow measurement.

The ACF6000 can measure most of the liquids; the infrared light sensor makes it easy for you to set parameters & change the display data. The Double-C tube & Double-D Tube make it possible for the meter to be used in most liquid applications.

## FEATURES

- ❑ Can be programmed by infrared light sensor without opening cover
- ❑ High turndown ratio of flow rate
- ❑ It comes any flanges such as ANSI, DIN, JIS... etc
- ❑ Excellent for high pressure application
- ❑ Simple for installation, commission and maintenance
- ❑ Self-diagnostic capabilities, cable faults, pipe vibration
- ❑ High accuracy of +/-0.2% of reading (or +/-0.1% of reading)
- ❑ With forward / reverse flow rate measurement function

## STANDARD SPECIFICATION

- Sensor Type : C tube (10-40mm) / U tube (50-150mm)
- Size : 10mm ~ 200 mm (3/8" ~ 8")
- Flow Range : 0 - 1000 Kg/Hr ~ 0 - 1106000 Kg/Hr
- Accuracy : +/-0.2% +/-ZS of reading (Standard)  
: +/-0.1% +/-ZS of reading (Optional)
- Repeatability : +/-0.03% +/-ZS of reading
- Density Range : 200 - 2300 Kg/M3 (0.2 - 2.3 g/cm3)  
Accuracy : +/-0.002 g/cm3
- Temperature Range : -40 °C ~ +125 °C (Standard)  
: -40 °C ~ +250 °C (Optional, Separate Only)
- Material  
Wetted Parts : Stainless Steel 316L  
Flange : Stainless Steel 316L  
Sensor Housing : Stainless Steel 304  
Junction Box : Aluminum Alloy (Epoxy Paint)
- Process Connection : Flange
- Flange Type : JIS 10K / JIS 20K / JIS 40K  
: ANSI 150# / ANSI 300# / ANSI 600#  
: DIN PN 10 / PN 16 / PN25 / PN 40
- Protection Class : IP 67  
: Explosion Proof Exde (ib) IIC T6 (Optional)
- Installation : Compact or Separate
- Signal Cable Length : 10M - 100M
- Display : 2 lines LCD with illumination  
Flow Rate Unit : g/s, Kg/min, kg/Hr, T/Hr, 5 Digit  
Density Unit : Kg/m3, g/cm3, 5 Digit  
Totalizer Unit : g, Kg, Ton, L, M3, 11 Digits  
Temperature : °C, °F, 4 Digits
- Keypad : Infrared light Sensor,  
can be programmed without  
Opening the cover
- Turndown Ratio : 20 : 1
- Damping : 0.01 To 1.0 Seconds
- Low Flow Cutoff : 0.0% ~ 9.0%
- Communication : RS485 (Modbus Protocol) (Standard)  
: Hart Signal (Optional)
- Current Output : 4-20 mA (Isolated)  
Load : Max. 750 Ω  
Output Unit : Mass / Volume / Density / Temperature
- Pulse (Alarm) Output : Open Collector  
Rating : 3-30Vdc, 50mA Max.
- Power Supply : 90-260 VAC, 50/60 Hz or 24 VDC +/-10%
- Power Consumption : 30 - 40 W (Depend on sensor size)
- Cable Entry : Sensor to Converter- 3/4" G  
: Signal output / Power supply- M20
- Ambient Temperature : -40 °C to +60 °C
- Max. Pressure : 63 Kg/cm2



**FLOW RANGE**

Unit : Kg/Hr

Normal Size		Flow Rate & Accuracy Table					
Model Code	Inch	Minimum	Normal	Maximum	Zero Stability	Temperature Effect %Flow Rate / °C	Pressure Effect %Flow Rate / Kg/cm2
0015	1/2"	100	1,000	2,000	0.17	+/-0.000125	-0.001
015L	1/2"(L)	300	3,000	6,000	0.40		
0020	3/4"	300	3,000	6,000	0.40		
0025	1"	630	6,300	12,600	0.90		
0040	1-1/2"	1,710	17,100	34,200	2.40	+/-0.0005	-0.003
0050	2"	6,330	63,300	126,600	8.30		
0065	2-1/2"	6,330	63,300	126,600	8.30		
0080	3"	16,100	161,000	322,000	19.0		
0100	4"	16,100	161,000	322,000	19.0	+/-0.001	-0.011
100L	4" (L)	36,200	362,000	724,000	48.0		
0125	5"	36,200	362,000	724,000	48.0		
0150	6"	36,200	362,000	724,000	48.0		
150L	6"(L)	55,300	553,000	1,106,000	78.0	+/-0.0025	-0.025
0200	8"	55,300	553,000	1,106,000	78.0		

Accuracy Between Minimum - Maximum is +/- 0.2% (+/- 0.1%) of Reading

**PRESSURE LOSS**

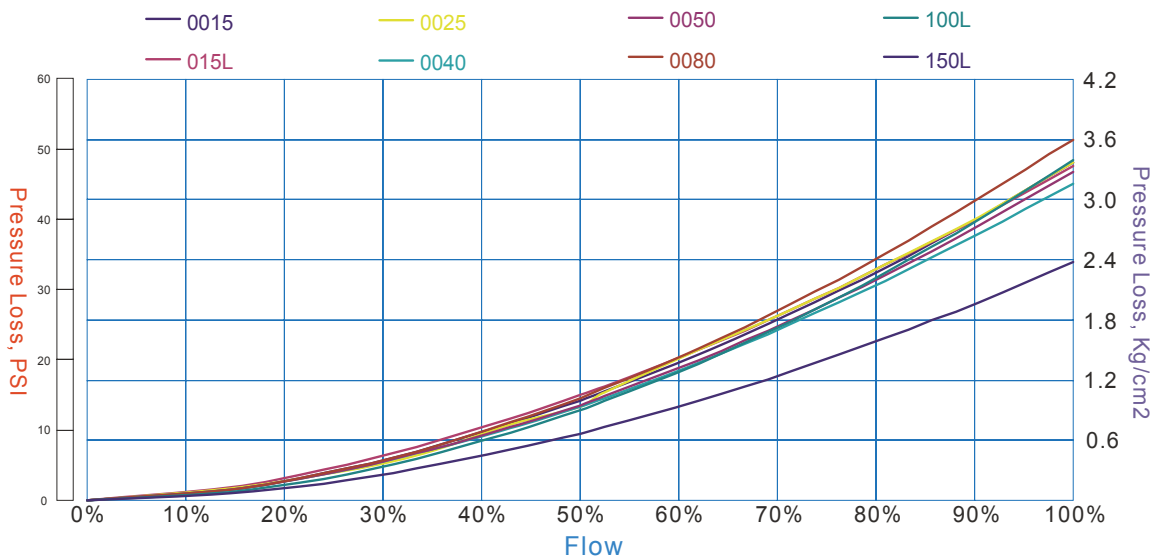

**WIRING DIAGRAM**

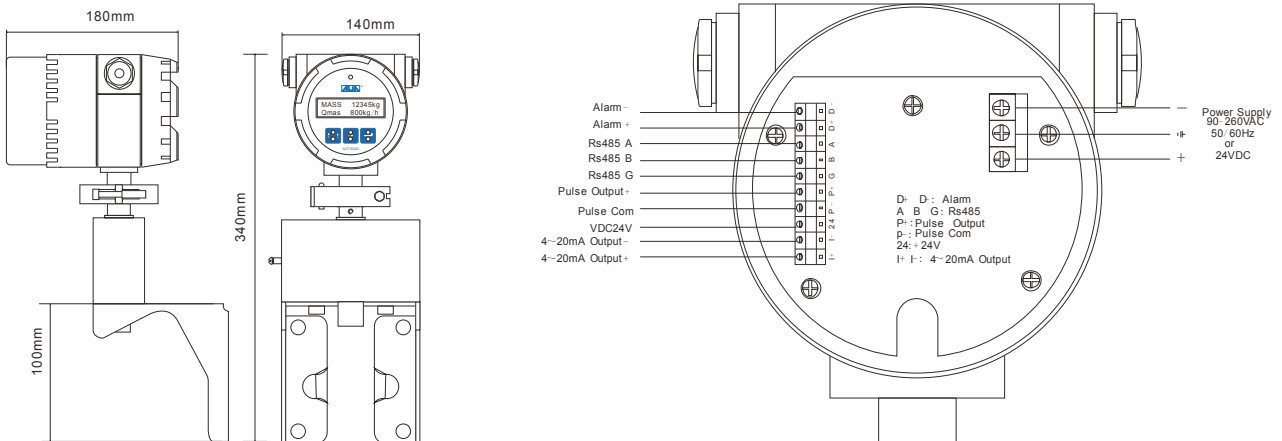

**➤ DIMENSIONS**

Normal Size		Standard Pressure kg/cm2	Dimensions (mm)							Sensor Weight Separate Type
mm	Inch		L	A	B	C	H	H1	E	KG
15	1/2"	40	162	320	170	223	436	357	76	6.5
15L	1/2"		162	370	190	250	458	379	94	7.5
25	1"		202	480	265	337	540	460	114	11
40	1.5"		274	615	295	383	563	513	146	21.5
50 / 65	2" - 2.5"		562 / 570	460	595	702	930	847	201	46
80 / 100	3" - 4"		850 / 864	774		937	310		214	89
100L / 150	4" - 6"		890 / 910	824		1135	285		264	208
150L / 200	6" - 8"		1090/1116	950		1050	285		290	248

Note: Standard Dimension L only for DIN flange

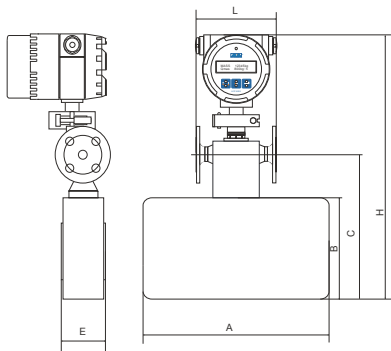

DN15-40

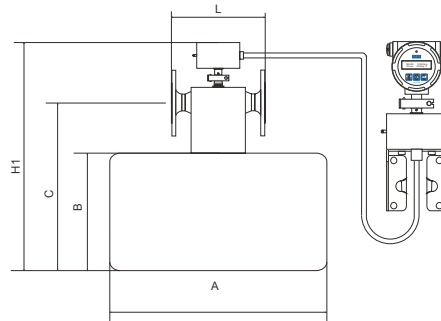

DN15-40

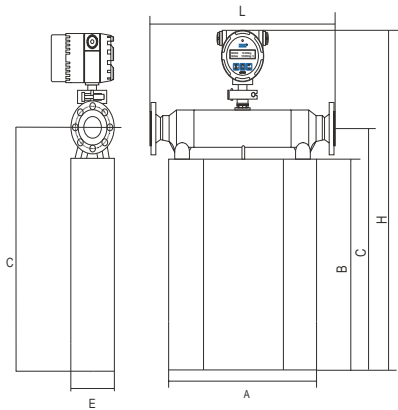

DN50 - DN65

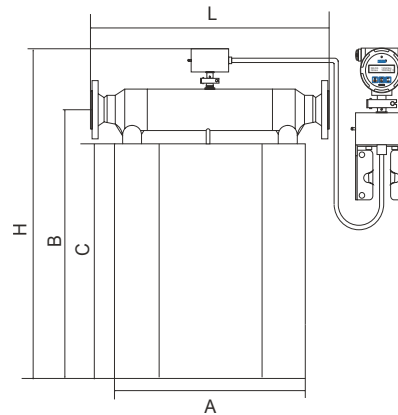

DN50 - DN65

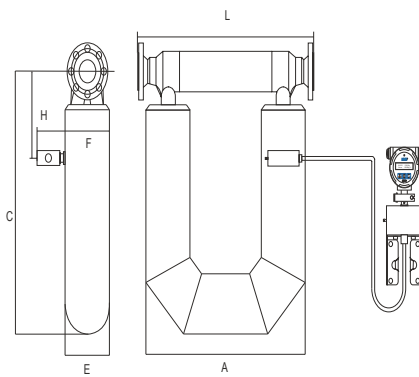

DN80

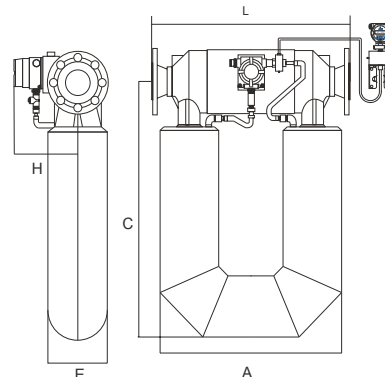

DN100 - DN200

**MODEL SELECTION GUIDE**

ACF6000 Series									
Example: ACF6000-0080-AH-020-H-AC-HT/EX/PT									
ACF6000-	XXXX	-X	X-	XXX	-X	-XX	-XX	Description	
Size	0015-0200							0015 / 015L / 0020 / 0025 / 0040 / 0050 / 0065 mm	
								0080 / 0100 / 100L / 125 / 150 / 150L / 200 mm	
Process Connection	-1							PN10	
	-2							PN16	
	-3							PN25	
	-4							PN40	
	-A							ANSI 150 #	
	-B							ANSI 300 #	
	-C							ANSI 600 # (Max. Pressure 63 Kg/cm <sup>2</sup> )	
	-J							JIS 10K	
	-K							JIS 20K	
	-L							JIS 40K	
-Z							Other		
Max. Temperature	N-							-40 °C ~ +125 °C	
	H-							-40 °C ~ 200 °C (Separate Type Only)	
	X-							-40 °C ~ 250 °C (Separate Type Only)	
Installation & Cable Length	NNN							Compact Version (Size 15 / 20 / 25 / 40 / 50 / 65mm Only)	
	010~100							Separate Version, Cable 10M ~ 100M, 2" Mounting Bracket	
Accuracy	-N							+/- 0.2% of reading	
	-H							+/- 0.1% of reading	
Power Supply	-AC							90 - 260 VAC, 50/60 Hz	
	-DC							24 VDC +/-10%	
Option	-NN							None	
	-HT							HART Signal	
	-EX							Explosion Proof, Exde (ib) IIC T6	
	-HJ							Heating Jacket	
	-PT							Cable Entry 1/2" NPTF	

**WORKING PRINCIPLE**

